

NOTES: UNLESS OTHERWISE SPECIFIED

1. ELECTRICAL SPECIFICATIONS:

FREQUENCY RANGE: 5.150-5.925 GHz

GAIN: 5 dBi

2. ALL MATERIALS AND PROCESSES MUST BE ROHS COMPLIANT

3. PARTS SHALL BE PACKAGED TO PREVENT DAMAGE IN SHIPMENT AND HANDLING.

4. A (REF) DIMENSION IS FOR INFORMATION PURPOSES ONLY AND NO TOLERANCE IS IMPLIED.

REVISION HISTORY			
REV	DESCRIPTION	DATE	APPROVED
1	OUTLINE DIMENSIONAL DRAWING	16MAY17	IP

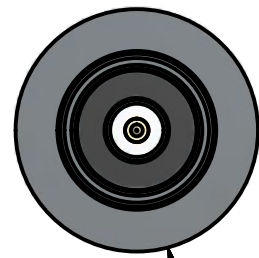

(Ø1.26 [32.0])

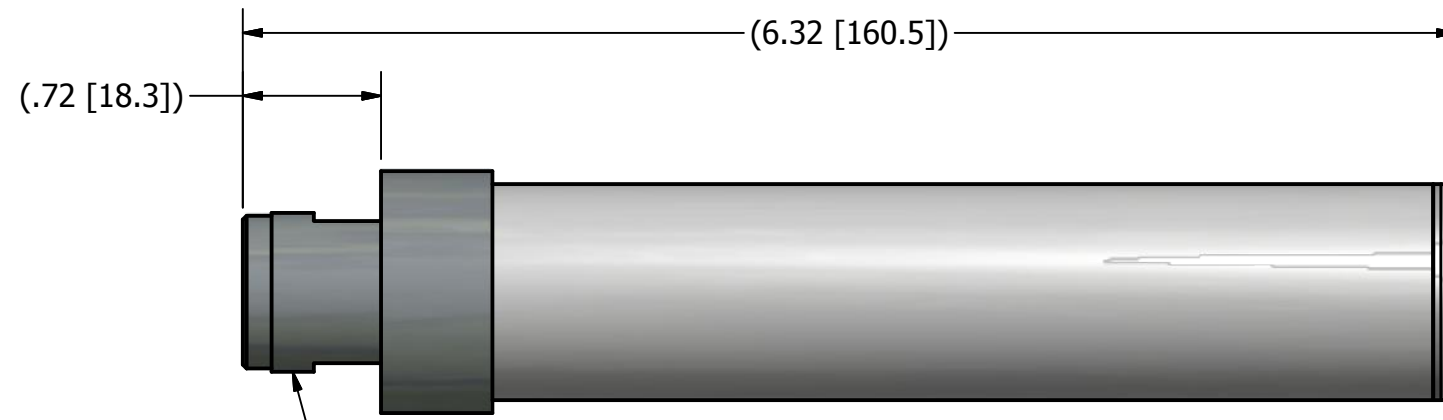

N MALE CONNECTOR

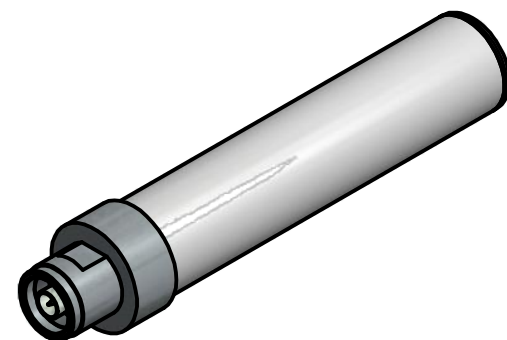

ISO VIEW
SCALE 1 / 2

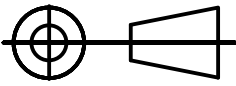
SUPPLIER PRINT ACCEPTANCE: <input type="checkbox"/> Accept drawing/specification: No changes needed: <input type="checkbox"/> This part is RoHS compliant <input type="checkbox"/> This part is REACH compliant <input type="checkbox"/> Accept drawing/specification. Notes/Mark-ups added <input type="checkbox"/> Cannot accept drawing/spec. Notes/Mark-ups added Supplier Projected Outgoing Quality: SIGMA LEVEL : _____ or PPM: _____ Signature _____ Date: _____	UNLESS OTHERWISE SPECIFIED DUAL DIMENSIONING XX.Xin [XX.Xmm] FOR TOLERANCES NOT SPECIFIED USE: X.X in ± .1 in, X.XX in ± .01 in, X.XXX in ± .005 in [X mm ± 3 mm], [X.X mm ± .3 mm], [X.XX mm ± .13 mm] ANGULAR ± 1°, FRACTIONAL ± 1/64	DRAWN IP DATE 5/16/2017 CHECKED _____ DATE _____	 PCTEL, INC. 471 BRIGHTON DRIVE BLOOMINGDALE, IL 60108 PH. 630-372-6800 FAX. 630-372-8077
	THIRD ANGLE PROJECTION 	MATERIAL: SEE COMP. PRINTS FINISH: SEE COMP. PRINTS	
PCTEL PROPRIETARY DATA THE INFORMATION AND/OR DRAWINGS CONTAINED IN THIS DOCUMENT IS CONFIDENTIAL AND PROPRIETARY TO PCTEL, INC. AND MAY NOT BE USED, REPRODUCED, IN WHOLE OR IN PART, OR MODIFIED IN ANY WAY WITHOUT THE EXPRESS WRITTEN PERMISSION OF AN AUTHORIZED REPRESENTATIVE OF PCTEL, INC.			DRAWING NO. ODD_BOAH515905NM
SIZE B		SCALE 1:1	SHEET 1 OF 1

NOTES: UNLESS OTHERWISE SPECIFIED

1. ELECTRICAL SPECIFICATIONS:

FREQUENCY RANGE: 5.150-5.925 GHz

GAIN: 5 dBi

2. ALL MATERIALS AND PROCESSES MUST BE ROHS COMPLIANT

3. PARTS SHALL BE PACKAGED TO PREVENT DAMAGE IN SHIPMENT AND HANDLING.

4. A (REF) DIMENSION IS FOR INFORMATION PURPOSES ONLY AND NO TOLERANCE IS IMPLIED.

REVISION HISTORY			
REV	DESCRIPTION	DATE	APPROVED
1	OUTLINE DIMENSIONAL DRAWING	16MAY17	IP

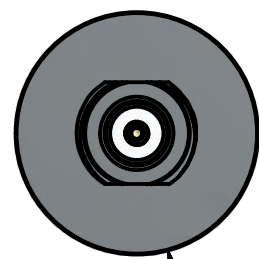

(Ø1.26 [32.0])

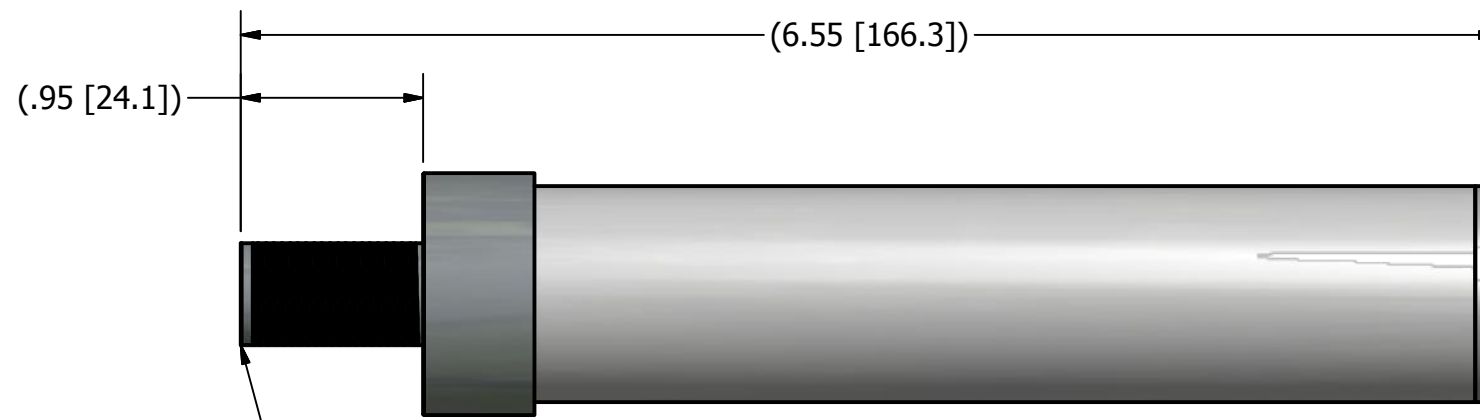



(.95 [24.1])

(6.55 [166.3])

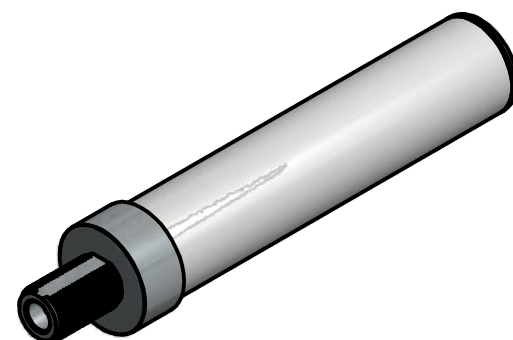
N FEMALE CONNECTOR

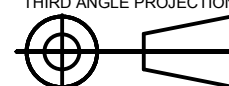

ISO VIEW
SCALE 1 / 2

SUPPLIER PRINT ACCEPTANCE: <input type="checkbox"/> Accept drawing/specification: No changes needed: <input type="checkbox"/> This part is RoHS compliant <input type="checkbox"/> This part is REACH compliant <input type="checkbox"/> Accept drawing/specification. Notes/Mark-ups added <input type="checkbox"/> Cannot accept drawing/spec. Notes/Mark-ups added Supplier Projected Outgoing Quality: SIGMA LEVEL : _____ or PPM: _____ Signature _____ Date: _____		UNLESS OTHERWISE SPECIFIED DUAL DIMENSIONING XX.Xin [XX.Xmm] FOR TOLERANCES NOT SPECIFIED USE: X.X in ± .1 in, X.XX in ± .01 in, X.XXX in ± .005 in [X mm ± 3 mm], [X.X mm ± .3 mm], [X.XX mm ± .13 mm] ANGULAR ± 1°, FRACTIONAL ± 1/64 THIRD ANGLE PROJECTION 		DRAWN IP DATE 5/16/2017 CHECKED _____ DATE _____ MATERIAL: SEE COMP. PRINTS FINISH: SEE COMP. PRINTS		 PCTEL, INC. 471 BRIGHTON DRIVE BLOOMINGDALE, IL 60108 PH. 630-372-6800 FAX. 630-372-8077	
PCTEL PROPRIETARY DATA THE INFORMATION AND/OR DRAWINGS CONTAINED IN THIS DOCUMENT IS CONFIDENTIAL AND PROPRIETARY TO PCTEL, INC. AND MAY NOT BE USED, REPRODUCED, IN WHOLE OR IN PART, OR MODIFIED IN ANY WAY WITHOUT THE EXPRESS WRITTEN PERMISSION OF AN AUTHORIZED REPRESENTATIVE OF PCTEL, INC.				DESCRIPTION ANTENNA, OMNIDIRECTIONAL, 5.150-5.925 GHZ, 5 DBI, H-POL			
DRAWING NO. ODD_BOAH515905NF		SIZE B SCALE 1:1 SHEET 1 OF 1					

NOTES: UNLESS OTHERWISE SPECIFIED

1. ELECTRICAL SPECIFICATIONS:

FREQUENCY RANGE: 2.4-2.5 GHz

GAIN: 5 dBi

2. ALL MATERIALS AND PROCESSES MUST BE ROHS COMPLIANT

3. PARTS SHALL BE PACKAGED TO PREVENT DAMAGE IN SHIPMENT AND HANDLING.

4. A (REF) DIMENSION IS FOR INFORMATION PURPOSES ONLY AND NO TOLERANCE IS IMPLIED.

REVISION HISTORY

REV	DESCRIPTION	DATE	APPROVED
1	OUTLINE DIMENSIONAL DRAWING	19JUN17	IP

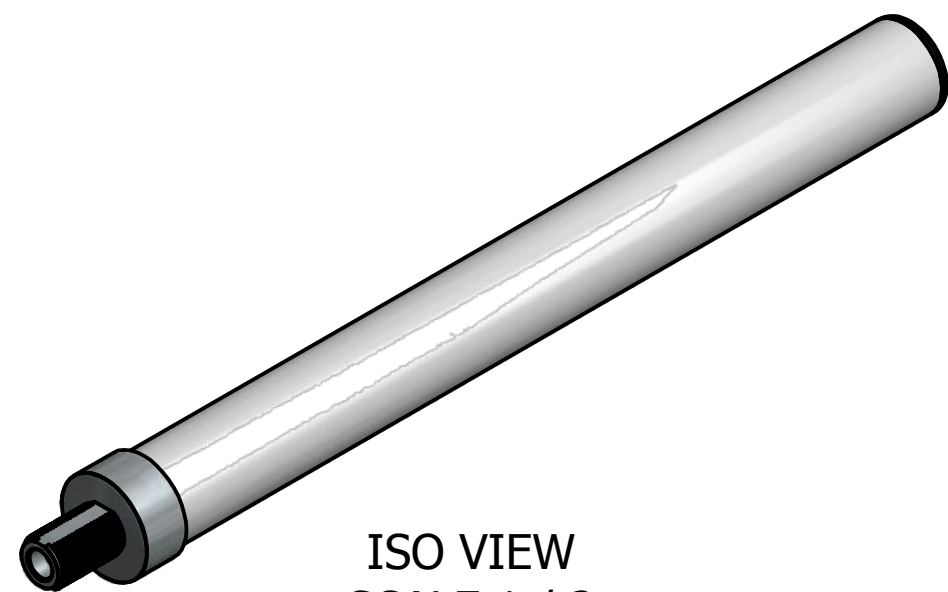
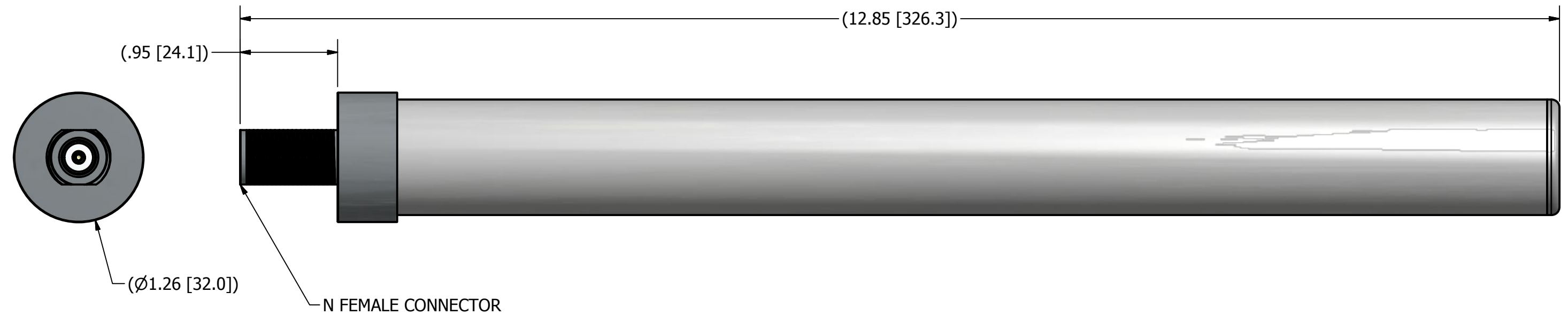

ISO VIEW
SCALE 1 / 2

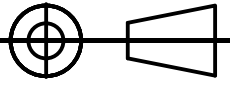
SUPPLIER PRINT ACCEPTANCE: <input type="checkbox"/> Accept drawing/specification: No changes needed: <input type="checkbox"/> This part is RoHS compliant <input type="checkbox"/> This part is REACH compliant <input type="checkbox"/> Accept drawing/specification. Notes/Mark-ups added <input type="checkbox"/> Cannot accept drawing/spec. Notes/Mark-ups added Supplier Projected Outgoing Quality: SIGMA LEVEL : _____ or PPM: _____ Signature _____ Date: _____	UNLESS OTHERWISE SPECIFIED DUAL DIMENSIONING XX.Xin [XX.Xmm] FOR TOLERANCES NOT SPECIFIED USE: X.X in ± .1 in, X.XX in ± .01 in, X.XXX in ± .005 in [X mm ± 3 mm], [X.X mm ± .3 mm], [X.XX mm ± .13 mm] ANGULAR ± 1°, FRACTIONAL ± 1/64	DRAWN IP DATE 6/19/2017 CHECKED _____ DATE _____ MATERIAL: SEE COMP. PRINTS FINISH: SEE COMP. PRINTS	 <p>PCTEL, INC. 471 BRIGHTON DRIVE BLOOMINGDALE, IL 60108 PH. 630-372-6800 FAX. 630-372-8077</p>
	THIRD ANGLE PROJECTION 	PCTEL PROPRIETARY DATA THE INFORMATION AND/OR DRAWINGS CONTAINED IN THIS DOCUMENT IS CONFIDENTIAL AND PROPRIETARY TO PCTEL, INC. AND MAY NOT BE USED, REPRODUCED, IN WHOLE OR IN PART, OR MODIFIED IN ANY WAY WITHOUT THE EXPRESS WRITTEN PERMISSION OF AN AUTHORIZED REPRESENTATIVE OF PCTEL, INC.	

NOTES: UNLESS OTHERWISE SPECIFIED

1. ELECTRICAL SPECIFICATIONS:
 FREQUENCY RANGE: 2.4-2.5 GHz
 GAIN: 5 dBi
2. ALL MATERIALS AND PROCESSES MUST BE ROHS COMPLIANT
3. PARTS SHALL BE PACKAGED TO PREVENT DAMAGE IN SHIPMENT AND HANDLING.
4. A (REF) DIMENSION IS FOR INFORMATION PURPOSES ONLY AND NO TOLERANCE IS IMPLIED.

REVISION HISTORY			
REV	DESCRIPTION	DATE	APPROVED
1	OUTLINE DIMENSIONAL DRAWING	16MAY17	IP

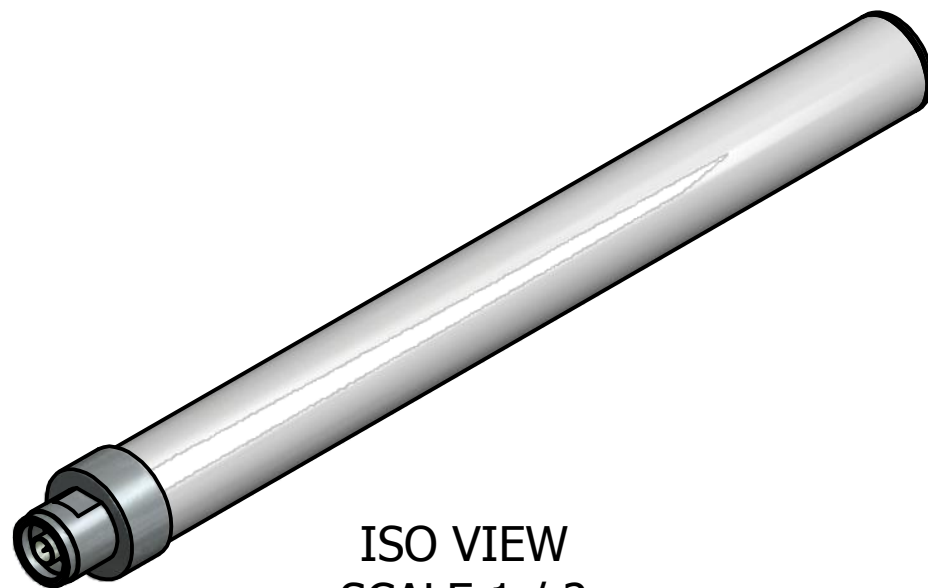
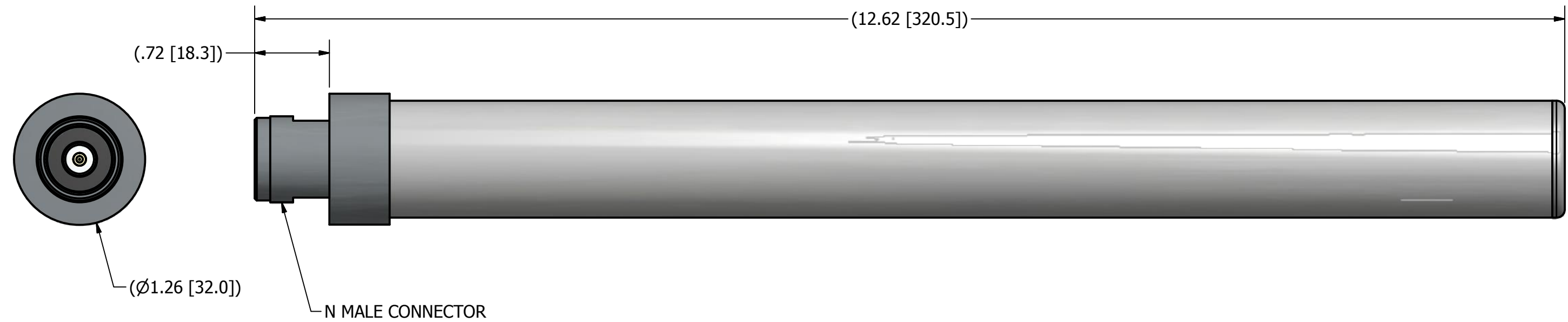

ISO VIEW
SCALE 1 / 2

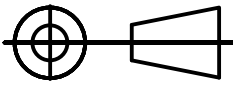
SUPPLIER PRINT ACCEPTANCE: <input type="checkbox"/> Accept drawing/specification: No changes needed: <input type="checkbox"/> This part is RoHS compliant <input type="checkbox"/> This part is REACH compliant <input type="checkbox"/> Accept drawing/specification. Notes/Mark-ups added <input type="checkbox"/> Cannot accept drawing/spec. Notes/Mark-ups added Supplier Projected Outgoing Quality: SIGMA LEVEL : _____ or PPM: _____ Signature _____ Date: _____	UNLESS OTHERWISE SPECIFIED DUAL DIMENSIONING XX.Xin [XX.Xmm] FOR TOLERANCES NOT SPECIFIED USE: X.X in ± .1 in, X.XX in ± .01 in, X.XXX in ± .005 in [X mm ± 3 mm], [X.X mm ± .3 mm], [X.XX mm ± .13 mm] ANGULAR ± 1°, FRACTIONAL ± 1/64	DRAWN IP DATE 5/16/2017 CHECKED _____ DATE _____ MATERIAL: SEE COMP. PRINTS FINISH: SEE COMP. PRINTS	 PCTEL, INC. 471 BRIGHTON DRIVE BLOOMINGDALE, IL 60108 PH. 630-372-6800 FAX. 630-372-8077
	THIRD ANGLE PROJECTION 	PCTEL PROPRIETARY DATA THE INFORMATION AND/OR DRAWINGS CONTAINED IN THIS DOCUMENT IS CONFIDENTIAL AND PROPRIETARY TO PCTEL, INC. AND MAY NOT BE USED, REPRODUCED, IN WHOLE OR IN PART, OR MODIFIED IN ANY WAY WITHOUT THE EXPRESS WRITTEN PERMISSION OF AN AUTHORIZED REPRESENTATIVE OF PCTEL, INC.	
DRAWING NO. ODD_BOAH242505NM			SIZE B SCALE 1:1 SHEET 1 OF 1